

TOP

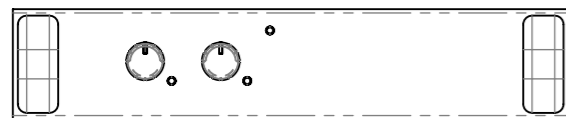

FRONT

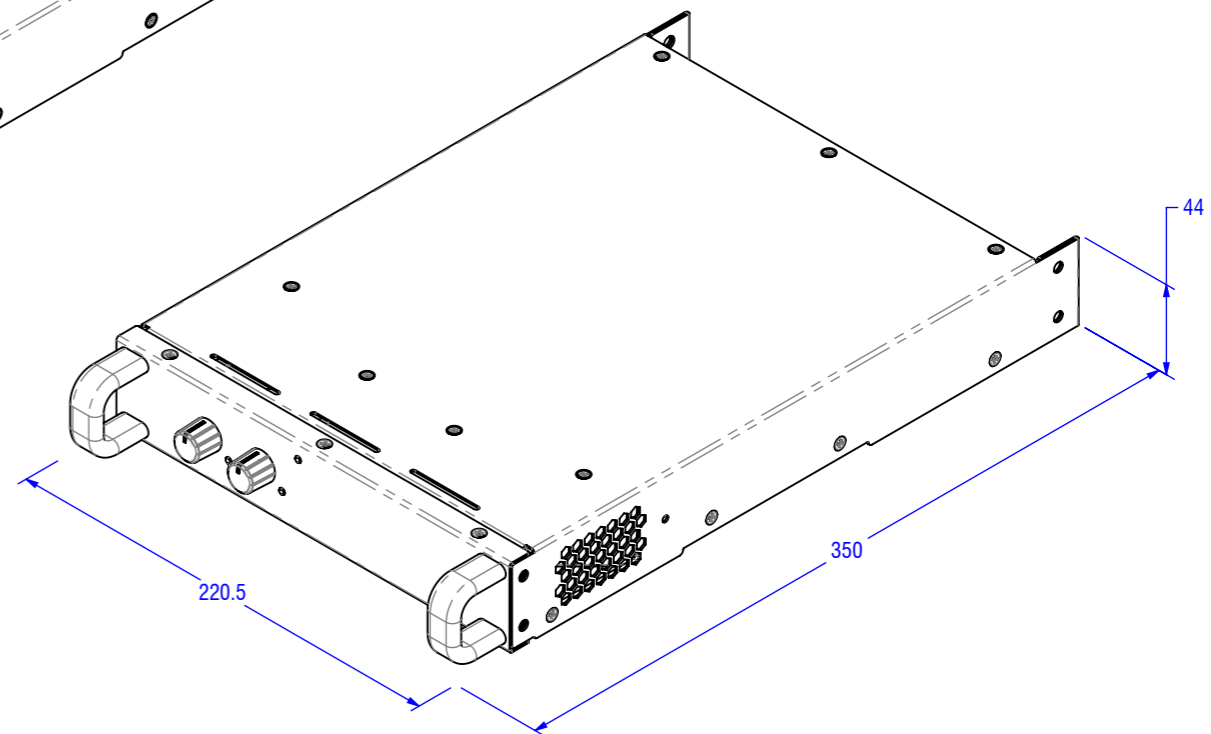
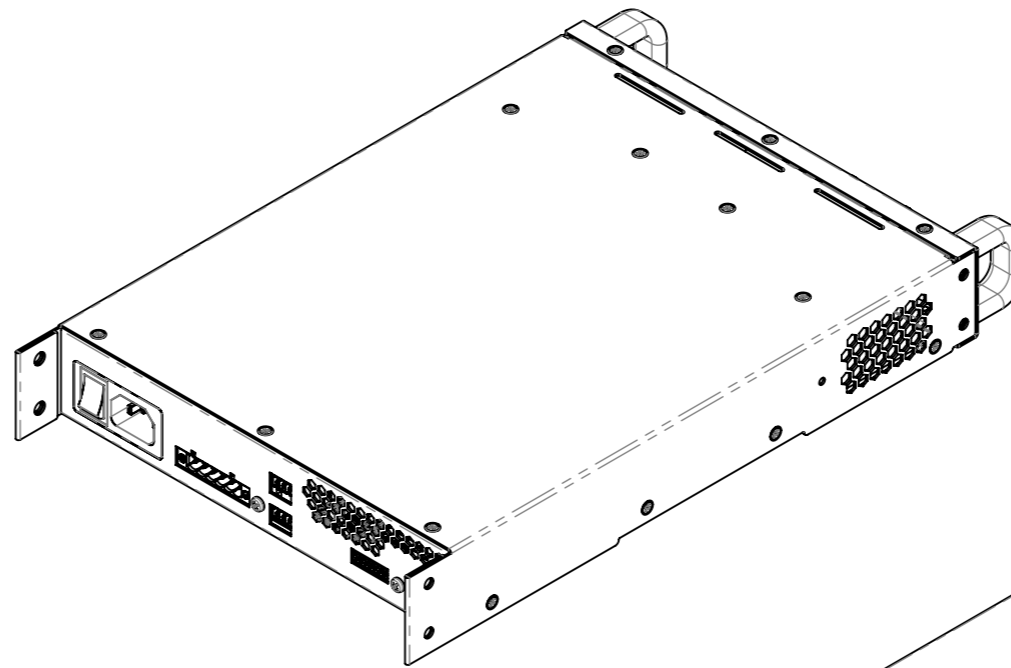

RIGHT

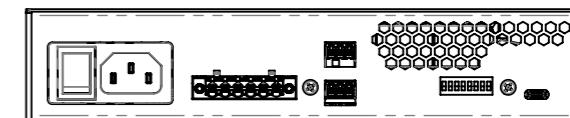

REAR

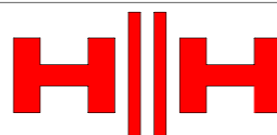

HH ELECTRONICS LTD  
 STEELPARK ROAD, COOMBS WOOD BUSINESS PARK,  
 HALESOWEN, WEST MIDLANDS, B62 8HD, UK  
 WWW.HHELECTRONICS.CO.UK

DESCRIPTION:  
**FULL ASSEMBLY**

STATE:  
**RELEASED**



UNLESS OTHERWISE STATED:  
 ALL DIMENSIONS ARE IN MILLIMETERS (mm)  
 LINEAR TOLERANCE  $\pm 0.5$  ANGULAR TOLERANCE  $\pm 1.0^\circ$

PROJECT TITLE:  
**MZ-140DX**

CUSTOMER INFORMATION

THIS DRAWING REMAINS THE PROPERTY OF HH ELECTRONICS LIMITED.  
 THIS DRAWING, HARD COPY OR DIGITAL, AND ANY ATTACHMENTS ARE  
 CONFIDENTIAL, LEGALLY PRIVILEGED AND PROTECTED BY COPYRIGHT.

DWG NO.  
**MCD017341**

DATE:  
**29/05/2025**

SCALE:  
**1:3**

SHEET SIZE:  
**A3**

REVISION:  
**2**

RELEASED BY:  
**TB**

SHEET:  
**1/1**