

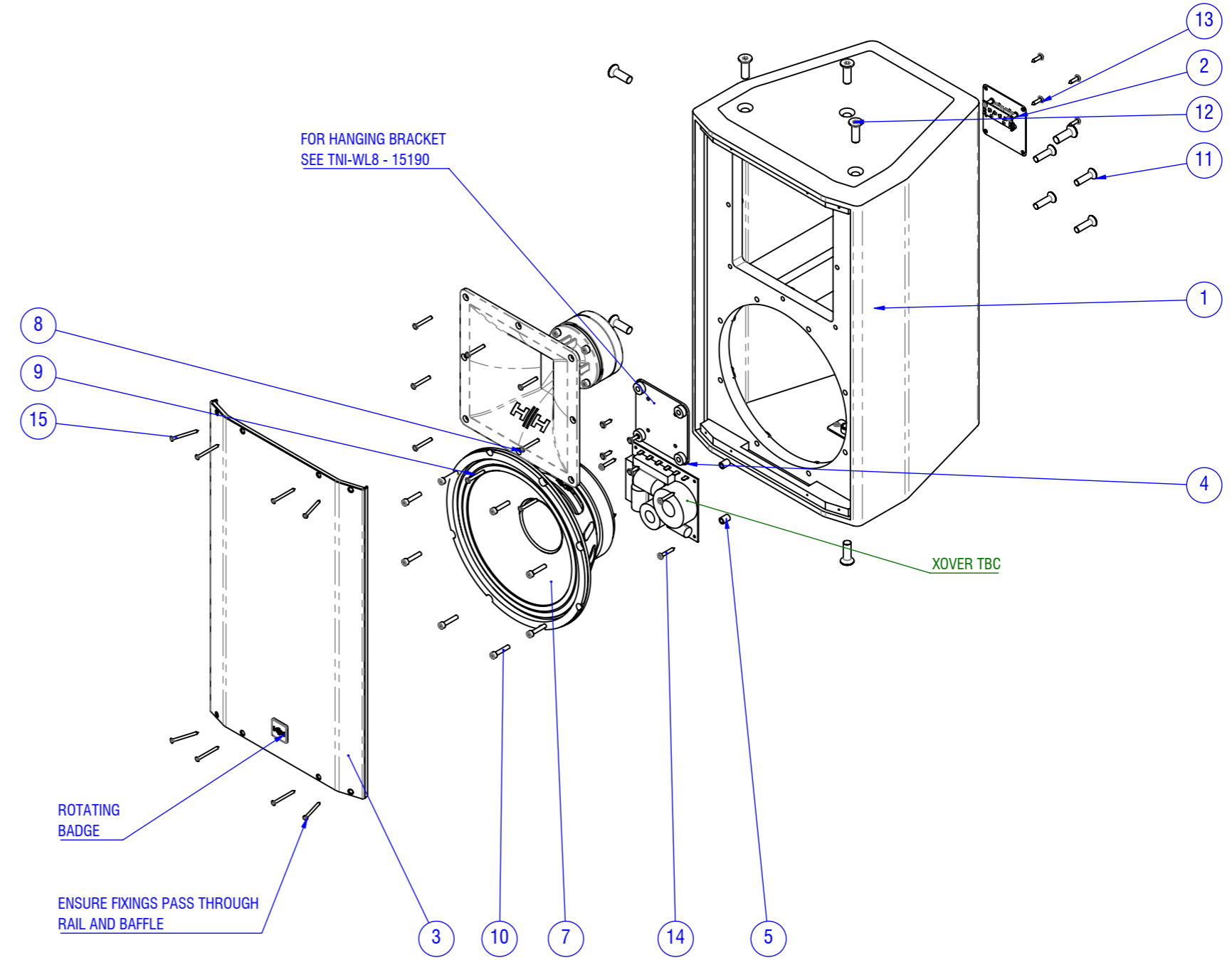

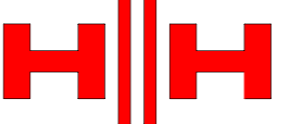



ITEM NO.	Part Number	DESCRIPTION	Revision	QTY.
1	MCA016373	Cabinet Assembly - Black	1	1
2	MCA016378	Rear Panel Assembly - TNi-W10PRO	2	1
3	MCA016376	Grille Assembly - Black	1	1
4	MCM015190	Hanging Plate	1	1
5	MCM015010	Round Plastic Spacer	-	4
6	MCA015817	Xover PCB - TNi-W12PRO	-	1
7	MCT016372	PA10-200 8 Ohm	-	1
8	MCA015199	LAB14082_A - Horn - CDX1-1445	2	1
9	MCM016371	M4 x 30mm - CSK Head - Hex - Machine Screw - Black	-	8
10	MCM015107	M5 x 25mm - Cap Head - Hex - Machine Screw - Black	-	8
11	MCM015194	M8 x 30mm - CSK Head - Hex - Machine Screw - Black	-	4
12	MCM015195	M10 x 30mm - CSK Head - Hex - Machine Screw - Black	-	7
13	MCM014615	(No.8) 4mm x 16mm - Pan Head - Cross - Wood Screw - Black	-	8
14	MCM015196	(No.8) 4mm x 25mm - Pan Head - Cross - Wood Screw - Black	-	4
15	MCM015388	(No.6) 3.5mm x 40mm - CSK Head - Hex - Wood Screw - Black	-	8

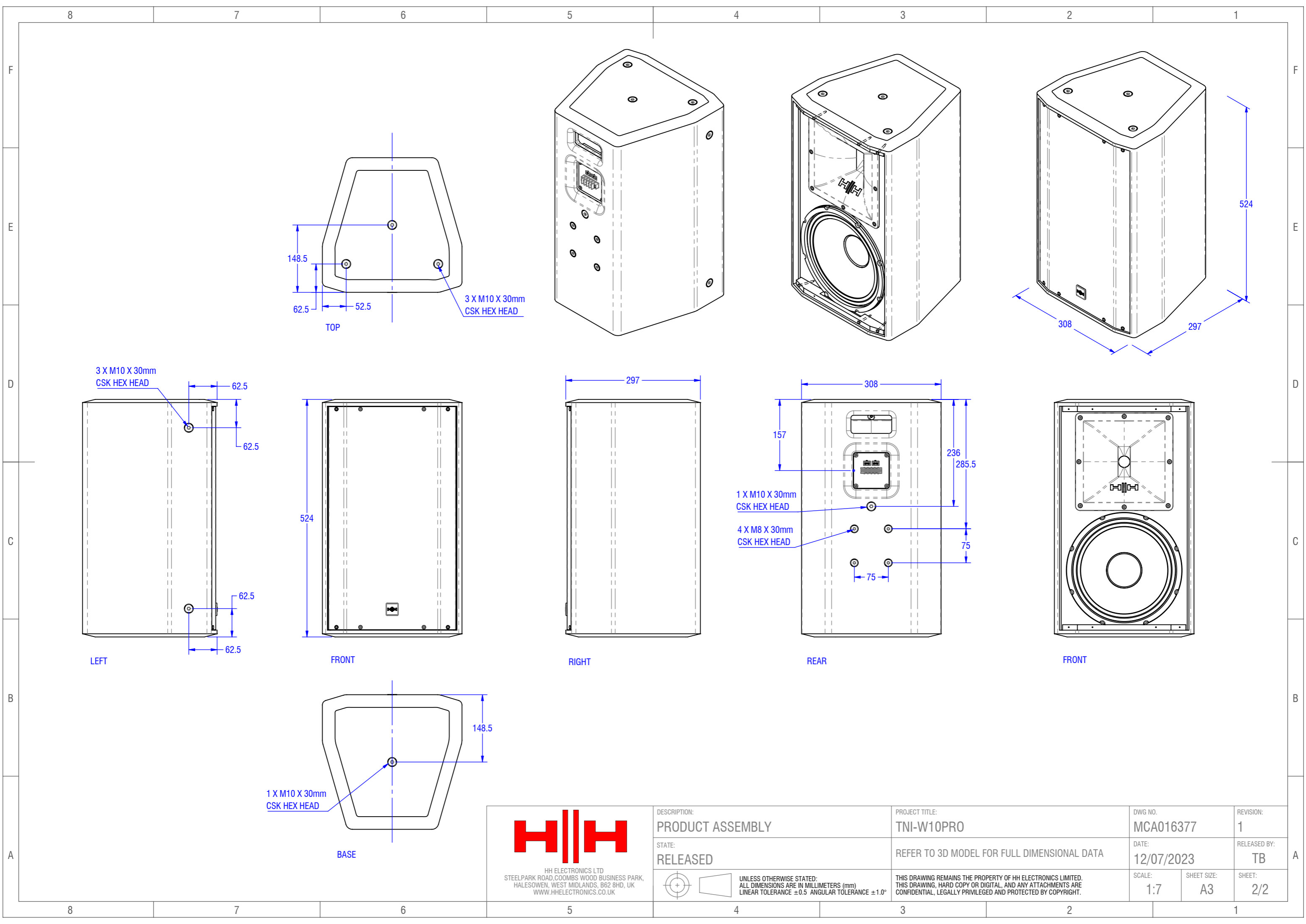

 HH ELECTRONICS LTD STEELPARK ROAD, COOMBS WOOD BUSINESS PARK, HALESOWEN, WEST MIDLANDS, B62 8HD, UK WWW.HHELECTRONICS.CO.UK	DESCRIPTION: PRODUCT ASSEMBLY	PROJECT TITLE: TNi-W10PRO	DWG NO. MCA016377	REVISION: 1	
	STATE: RELEASED	REFER TO 3D MODEL FOR FULL DIMENSIONAL DATA		DATE: 12/07/2023	RELEASED BY: TB
	 UNLESS OTHERWISE STATED: ALL DIMENSIONS ARE IN MILLIMETERS (mm) LINEAR TOLERANCE ± 0.5 ANGULAR TOLERANCE $\pm 1.0^\circ$	THIS DRAWING REMAINS THE PROPERTY OF HH ELECTRONICS LIMITED. THIS DRAWING, HARD COPY OR DIGITAL, AND ANY ATTACHMENTS ARE CONFIDENTIAL, LEGALLY PRIVILEGED AND PROTECTED BY COPYRIGHT.		SCALE: 1:7	SHEET SIZE: A3



 HH ELECTRONICS LTD STEELPARK ROAD, COOMBS WOOD BUSINESS PARK, HALESOWEN, WEST MIDLANDS, B62 8HD, UK WWW.HHELECTRONICS.CO.UK	DESCRIPTION: PRODUCT ASSEMBLY	PROJECT TITLE: TNI-W10PRO	DWG NO. MCA016377	REVISION: 1
	STATE: RELEASED	REFER TO 3D MODEL FOR FULL DIMENSIONAL DATA	DATE: 12/07/2023	RELEASED BY: TB
  UNLESS OTHERWISE STATED: ALL DIMENSIONS ARE IN MILLIMETERS (mm) LINEAR TOLERANCE ± 0.5 ANGULAR TOLERANCE $\pm 1.0^\circ$	THIS DRAWING REMAINS THE PROPERTY OF HH ELECTRONICS LIMITED. THIS DRAWING, HARD COPY OR DIGITAL, AND ANY ATTACHMENTS ARE CONFIDENTIAL, LEGALLY PRIVILEGED AND PROTECTED BY COPYRIGHT.	SCALE: 1:7	SHEET SIZE: A3	SHEET: 2/2