

ITEM NO.	Part Number	DESCRIPTION	Revision	QTY.
1	MCA016377	Product Assembly	1	1
2	MCA016392	Packing Tray Assembly	1	2
3	MCM016396	Product Carton	1	1
4	MCM016397	Shipping Carton	1	1
5	MCD013731	HH User Manual Download Card	-	1
6	MCM016398	Packing Bag	1	1

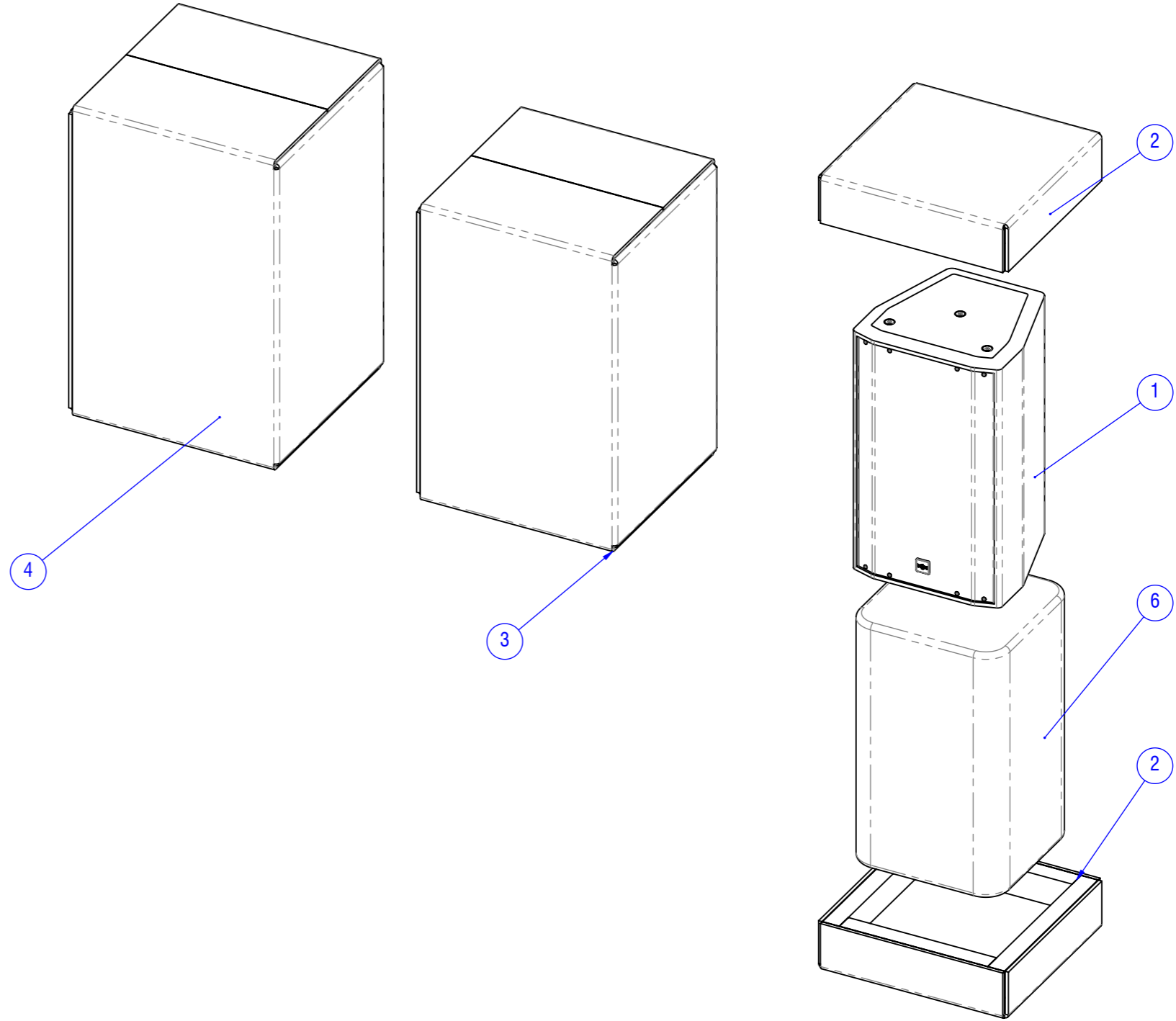

- NOTES**
- ALL DIMENSIONS IN mm UNLESS STATED
 - IMPORTANT! CARTON INTERNAL SIZE SHOWN (EXTERNAL DIMS IN []).
 - CARDBOARD TO BE HEAVY DUTY AB TYPE MINIMUM 7mm THICK.
 - CABINET TO BE A 'GOOD' FIT INTO CARTON, NO MOVEMENT AFTER SEALING.
 - PACKING TRAYS ARE 7mm THICK CARD WITH EPE FOAM PADS.



DESCRIPTION:
PACKAGING ASEMBLY

STATE:
RELEASED



UNLESS OTHERWISE STATED:
ALL DIMENSIONS ARE IN MILLIMETERS (mm)
LINEAR TOLERANCE ± 0.5 ANGULAR TOLERANCE $\pm 1.0^\circ$

PROJECT TITLE:
TNI-W10PRO

REFER TO 3D MODEL FOR FULL DIMENSIONAL DATA

THIS DRAWING REMAINS THE PROPERTY OF HH ELECTRONICS LIMITED.
THIS DRAWING, HARD COPY OR DIGITAL, AND ANY ATTACHMENTS ARE
CONFIDENTIAL, LEGALLY PRIVILEGED AND PROTECTED BY COPYRIGHT.

DWG NO.
MCA016393

DATE:
13/07/2023

SCALE:
1:10

REVISION:
1

RELEASED BY:
TB

SHEET SIZE:
A3

SHEET:
1/2

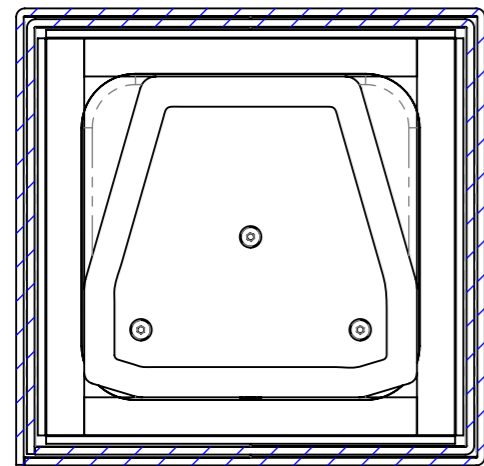

TOP

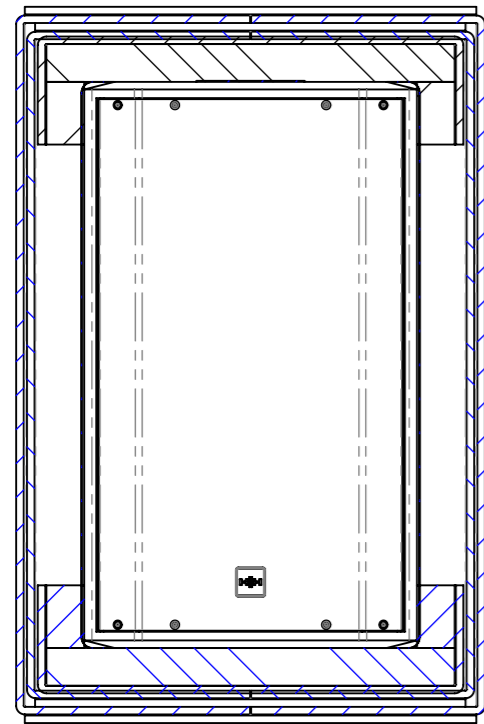

FRONT

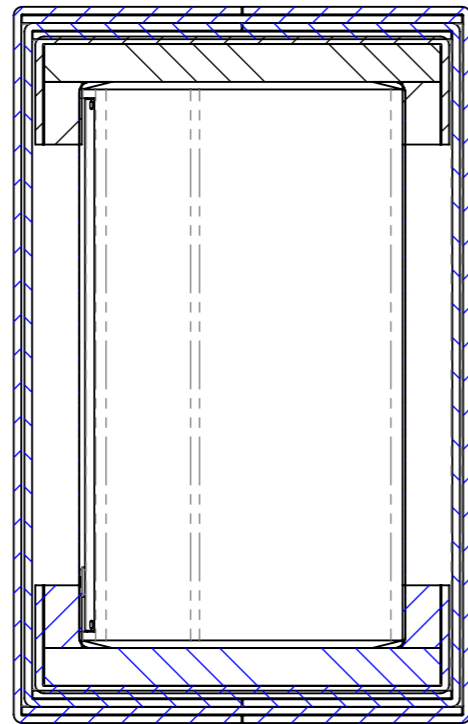

RIGHT

SHIPPING CARTON

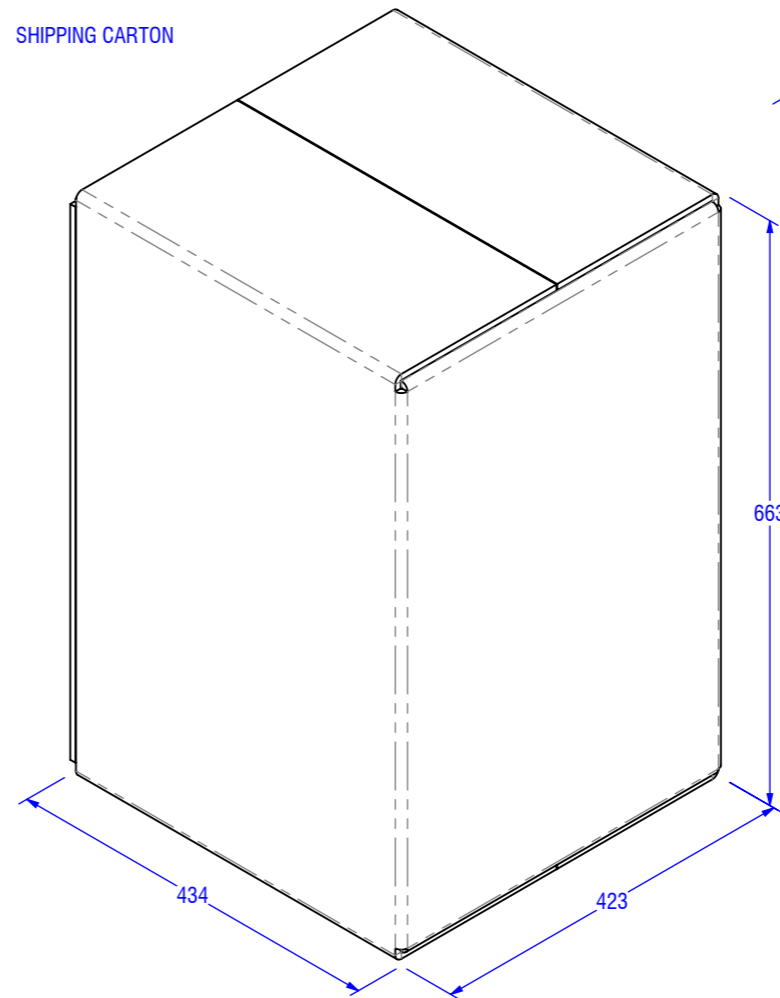

PRODUCT CARTON

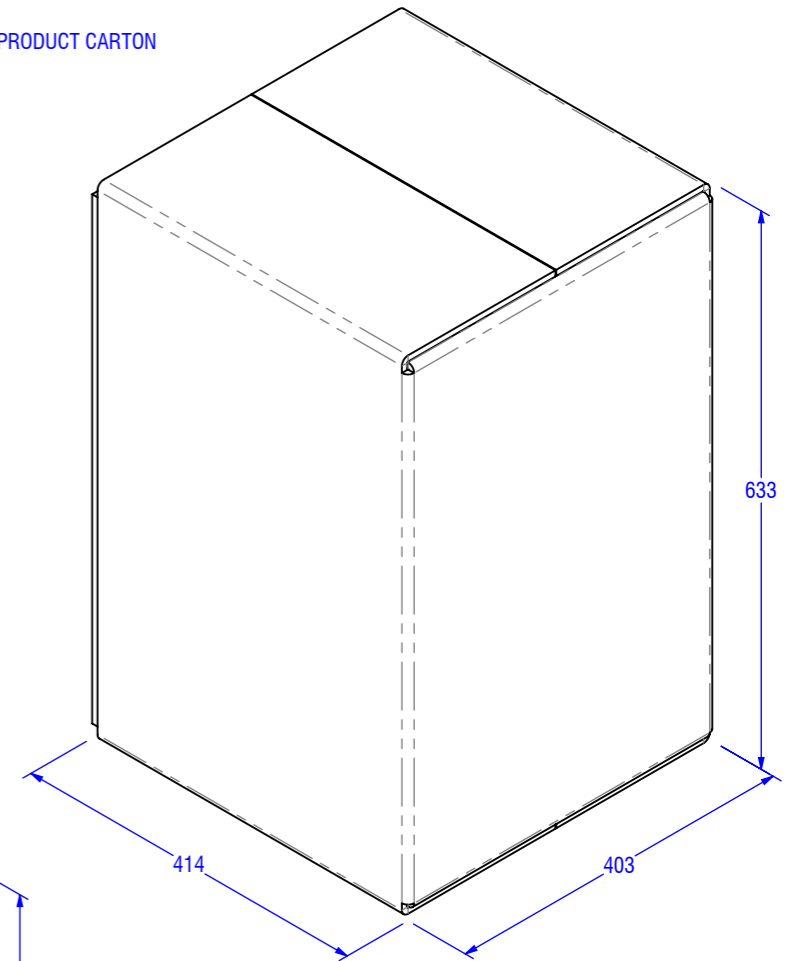

HH ELECTRONICS LTD
 STEELPARK ROAD, COOMBS WOOD BUSINESS PARK,
 HALESOWEN, WEST MIDLANDS, B62 8HD, UK
 WWW.HHELECTRONICS.CO.UK

DESCRIPTION:
PACKAGING ASEMBLY

STATE:
RELEASED



UNLESS OTHERWISE STATED:
 ALL DIMENSIONS ARE IN MILLIMETERS (mm)
 LINEAR TOLERANCE ± 0.5 ANGULAR TOLERANCE $\pm 1.0^\circ$

PROJECT TITLE:
TNI-W10PRO

REFER TO 3D MODEL FOR FULL DIMENSIONAL DATA

THIS DRAWING REMAINS THE PROPERTY OF HH ELECTRONICS LIMITED.
 THIS DRAWING, HARD COPY OR DIGITAL, AND ANY ATTACHMENTS ARE
 CONFIDENTIAL, LEGALLY PRIVILEGED AND PROTECTED BY COPYRIGHT.

DWG NO.
MCA016393

DATE:
13/07/2023

SCALE:
1:7

REVISION:
1

RELEASED BY:
TB

SHEET SIZE:
A3

SHEET:
2/2