

ITEM NO.	Part Number	DESCRIPTION	Revision	QTY.
1	MCM016419	Card Tray	1	1
2	MCM016420	EPE Tray	1	1

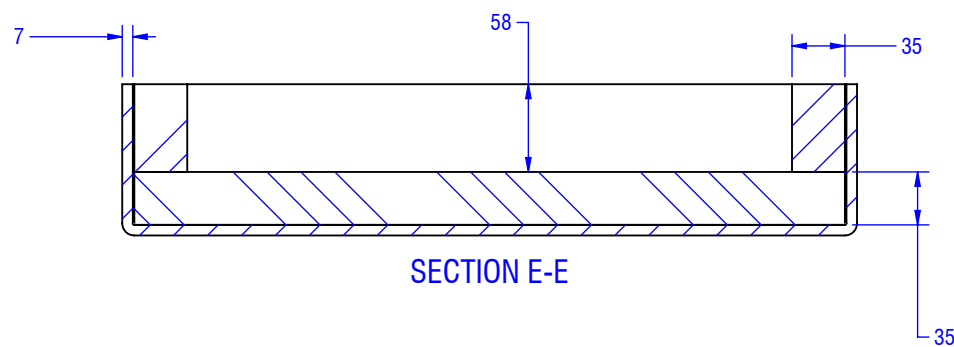
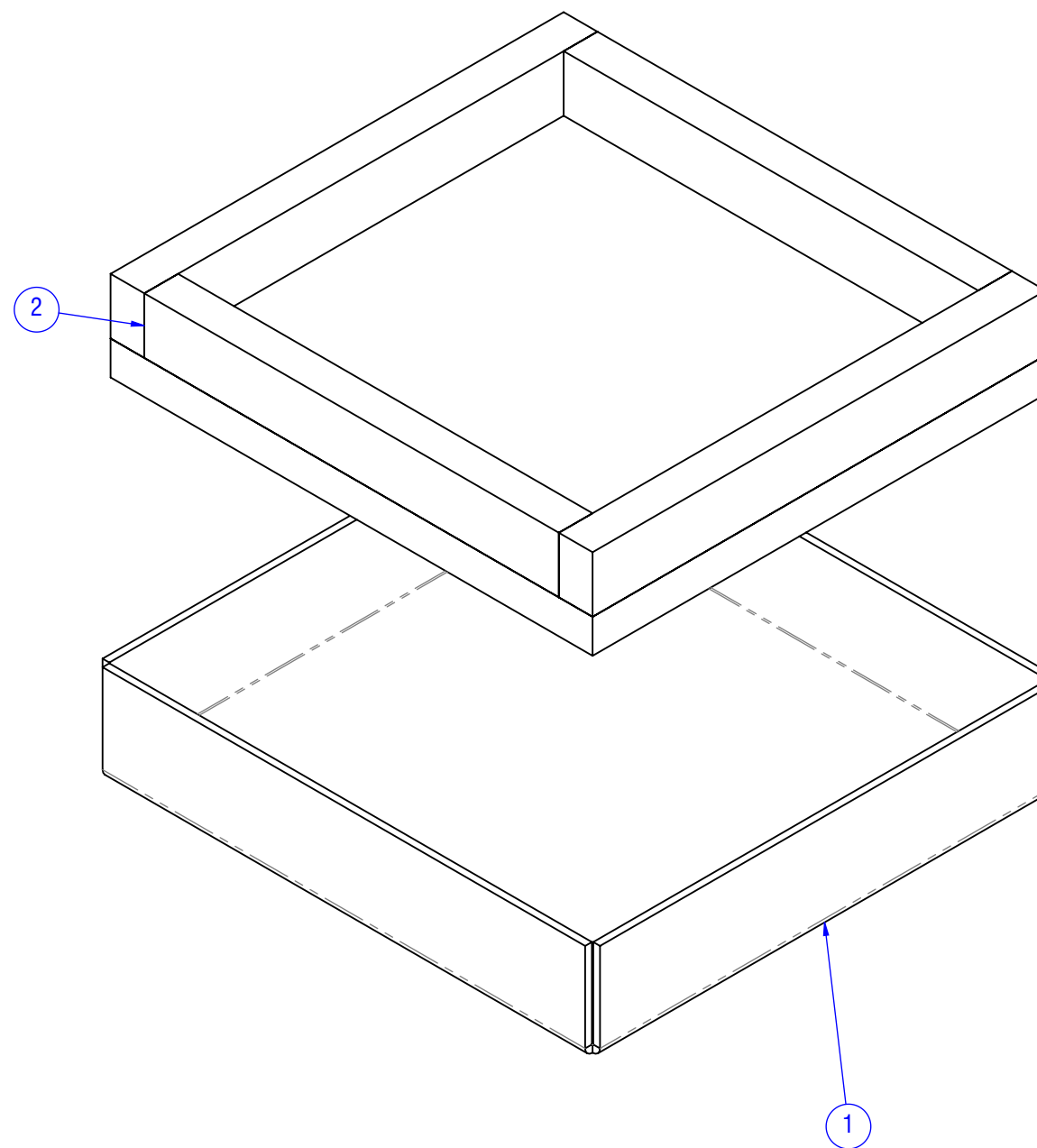
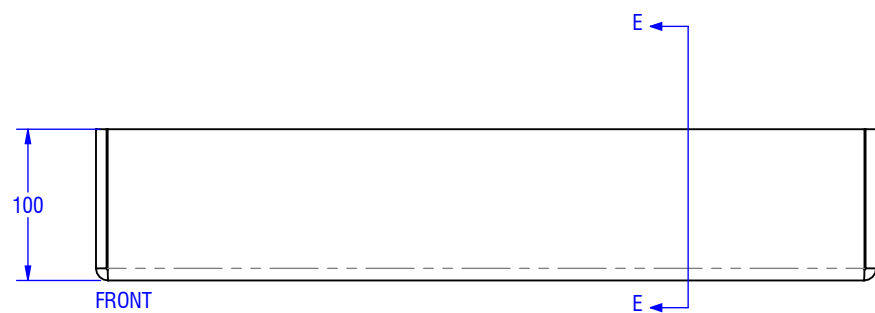
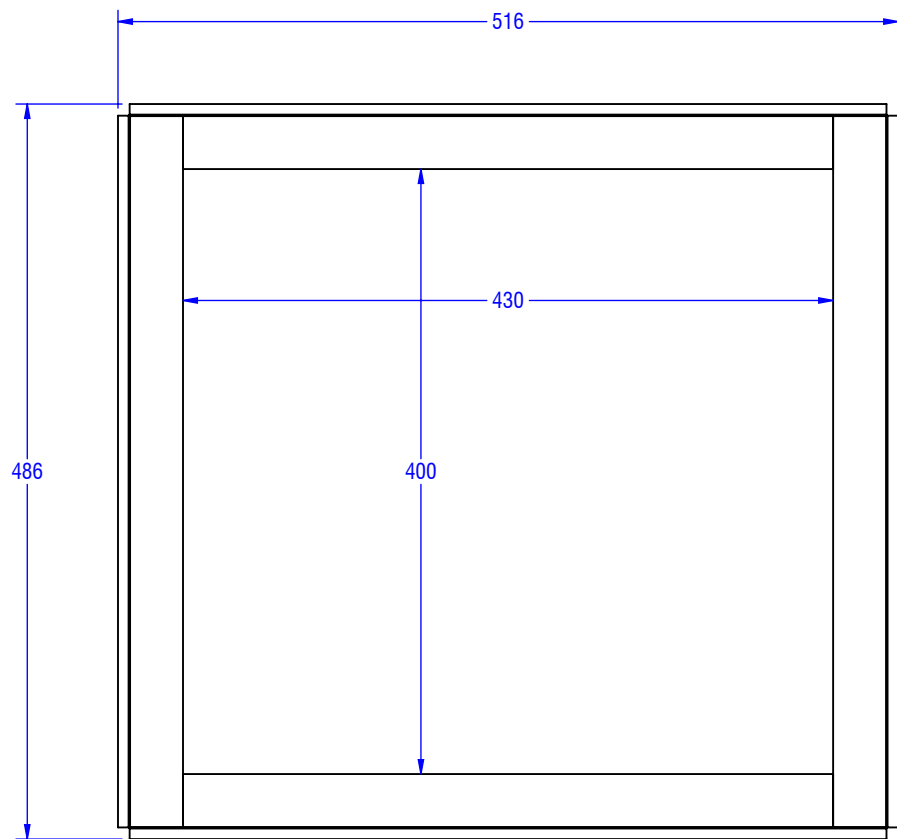

DESCRIPTION:
PACKING TRAY ASSEMBLY

STATE:
RELEASED

UNLESS OTHERWISE STATED:
ALL DIMENSIONS ARE IN MILLIMETERS (mm)
LINEAR TOLERANCE ± 0.5 ANGULAR TOLERANCE $\pm 1.0^\circ$

PROJECT TITLE:
TNI-W15PRO

REFER TO 3D MODEL FOR FULL DIMENSIONAL DATA

THIS DRAWING REMAINS THE PROPERTY OF HH ELECTRONICS LIMITED.
THIS DRAWING, HARD COPY OR DIGITAL, AND ANY ATTACHMENTS ARE
CONFIDENTIAL, LEGALLY PRIVILEGED AND PROTECTED BY COPYRIGHT.

DWG NO. MCA016417	REVISION: 1
DATE: 13/07/2023	RELEASED BY: TB
SCALE: 1:5	SHEET: 1/1

REVISIONS			
REV.	DESCRIPTION	DATE	APPROVED
8	7	6	