

TNi-WX5

2-Way Passive Point Source Loudspeaker

Features

- 5.25-inch low-frequency driver. 0.75-inch high-frequency driver.
- Power handling: 50W RMS
- Sensitivity (1W/1m): 87 dB
- IP65 weather-resistant design.
- Compact lightweight design for simple and discreet installation.
- Accessories: Cable gland panel, pan & tilt wall bracket.

Applications

- Commercial
- Corporate
- Retail
- Hospitality
- Education
- House of Worship



Description

The TNi-WX5 is a 2-way passive design featuring a 5.25-inch low-frequency driver and a 0.75-inch high-frequency driver that provide a beautifully balanced, natural and dynamic listening experience, with excellent speech intelligibility and exceptional detail for background music applications. With a sensitivity of 87dB (1W/1m) and a power handling of 50W RMS, the TNi-WX5 yields a max SPL of 103dB and is well suited to commercial spaces, hospitality venues, retail locations and outdoor environments.

The TNi-WX5 is designed for flexibility, suitable for Lo-Z systems with a nominal system impedance of 8 Ohms, and an internal line transformer with taps from 15W down to 2.5W expanding the potential applications to include large-scale 70/100V audio systems.

The TNi-WX5 is built for durability when used in both indoor and outdoor applications, featuring a cabinet constructed from UV-resistant ABS, an aluminium grille and a rear cable gland panel. These features combine to achieve an IP rating of IP65, making this an ideal weather-resistant audio solution.

The compact form factor (256 x 166 x 163mm), lightweight design (2.3kg) and included pan & tilt wall bracket all contribute to a fast and simple installation.

Dimensions

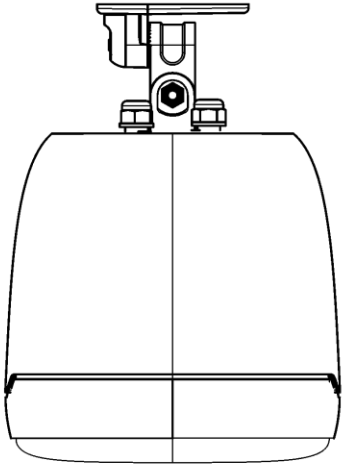

Top

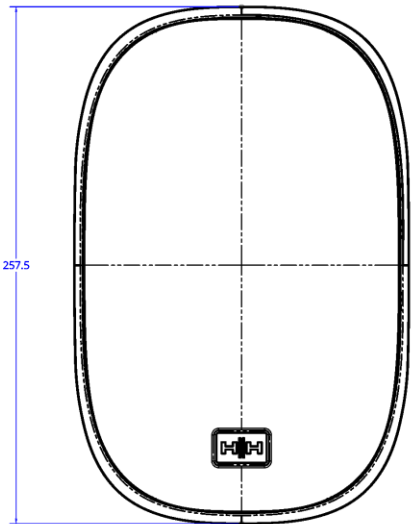
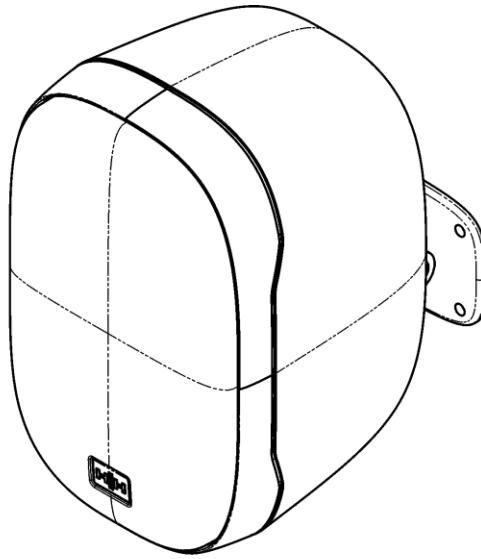

257.5

Front

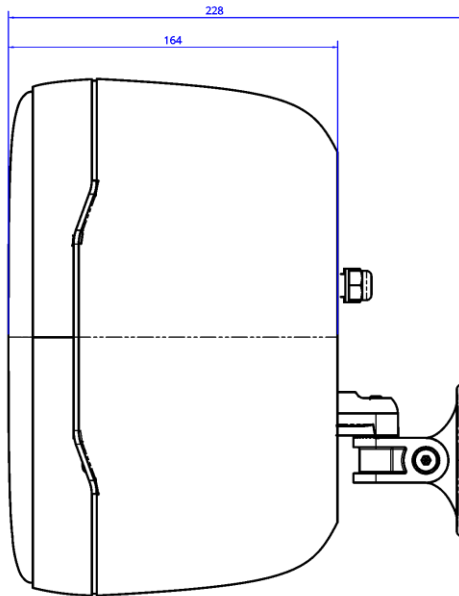

228

164

Right

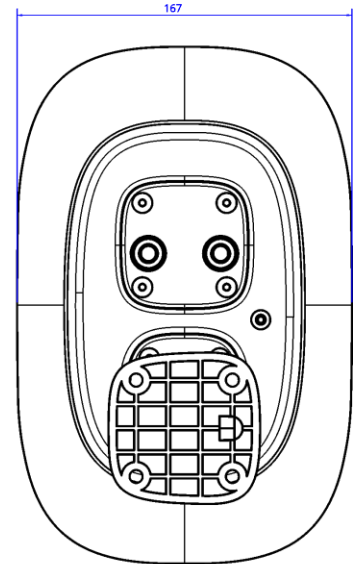

167

Back

Specifications

Model	<i>TNi-WX5</i>
System type	<i>2-Way Passive Surface Mount Loudspeaker</i>
Woofer Size	<i>5.25-inch</i>
Tweeter Size	<i>0.75-inch</i>
Nominal System Impedance	<i>8 Ohms</i>
Power Rating ¹	<i>50W RMS, 200W Peak</i>
70V Transformer Tappings	<i>7.5W, 5W, 3.75W, 2.5W</i>
100V Transformer Tappings	<i>15W, 10W, 7.5W, 5W</i>
Recommended Amplifier	<i>MZ-140DX, MZ-140D, MZ-140Q or equivalent 70W - 140W @ 8 Ohm amplifier</i>
Sensitivity 1W/1m ²	<i>87dB</i>
Maximum SPL (1m) ³	<i>103dB</i>
Frequency response (-10dB)	<i>75Hz - 20kHz</i>
Input / Link Connector	<i>4-Pin Euroblock/Phoenix</i>
Horizontal Dispersion Angle	<i>120°</i>
Vertical Dispersion Angle	<i>100°</i>
Enclosure	
Main Construction Material	<i>ABS</i>
Finish	<i>Black or White</i>
Grille	<i>Aluminium</i>
IP Rating	<i>IP65</i>
Accessories	
Mounting Bracket	<i>Pan/Tilt wall bracket included</i>
Rear Panel	<i>Cable gland panel for outdoor use</i>
Unit dimensions (HWD)	<i>258 x 167 x 164mm, (10.2" x 6.6" x 6.5")</i>
Unit Dimensions with Bracket (HWD)	<i>258 x 167 x 228mm, (10.2" x 6.6" x 9")</i>
Unit weight	<i>2.4Kg, (5.3 lbs)</i>
Carton dimensions (HWD)	<i>395 x 240 x 240mm, (15.6" x 9.4" x 9.4"), 0.023 M3</i>
Packed weight	<i>3Kg, (6.6 lbs)</i>
Master Carton dimensions (HWD)	<i>405 x 485 x 490mm, (15.9" x 19.1" x 19.3"), 0.096 M3</i>
Master QTY	<i>4</i>
Master Packed weight	<i>13Kg, (28.7 lbs)</i>
EAN Code	<i>Black: 5061098770393, White: 5061098770409</i>

In the interest of continued development, HH reserves the right to amend product specification without prior notification.