

TNA ACTIVE SUBWOOFER

TNA-2800S

FEATURES

- High performance Dual 18 inch woofers for extended low-frequency output
- High power capacity to ensure impressive coverage without compression
- Robust all wood construction, hard wearing finish
- 4pcs Heavy duty 100mm PU castors included
- Large front ports reduced distortion
- Ergonomic Side Carry Handles

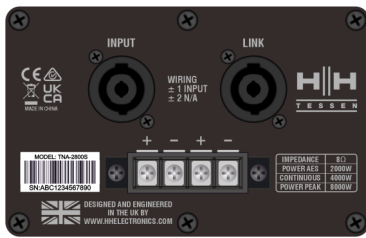

INPUT PANEL

APPLICATIONS

- Bars And Clubs
- Live Sound Reinforcement
- Sound system rental
- Worship

The TNA-2800S passive subwoofer harnesses two HH-designed 18" low-frequency woofers with 4" voice coils providing a max SPL of 138 dB SPL peak and a frequency response as low as 32Hz. The acoustically optimised cabinet is constructed of 18mm plywood with extensive internal bracing. Integrated rigging hardware makes the TNA-2800S the perfect solution for installed use in clubs, live music venues, and places of worship where high-output bass reinforcement is required. The included heavy-duty castors allow for easy transportation making the TNA-2800S suitable for touring.

SPECIFICATIONS

Model	TNA-2800S
System Type	Dual 18" passive Subwoofer, Direct Radiating, Bass Reflex
Frequency Response ²	32Hz - 120Hz (-10dB) 37Hz - 120Hz (-3dB)
Recommended Crossover	30Hz 24dB/Octave HPF, 80Hz 24dB/Octave LPF
Power Rating	8000W Peak, 4000W Continuous, 2000W RMS
Max SPL 1m3	138 db SPL Peak, 132 db SPL
Sensitivity (1W/1M)	99 dB SPL
LF Driver	2x18" High sensitivity HH designed driver. 4" Voice Coils
Nominal Impedance	8 Ohms
Input Connector	NL4 ± 1 Twist Lock Connector and M4 Barrier Strip Terminal (10mm Pitch)
Input Connector	NL4 ± 1 Twist Lock Connector and M4 Barrier Strip Terminal (10mm Pitch)
Enclosure	
Cabinet	Acoustically optimised 18mm plywood cabinet with extensive internal bracing
Finish	Painted Black (White finish optional, subject to MOQ)
Mounting Points	8x M10 Penn Elcom tie down/flying points. 16x M8 inserts for included transport wheels
Grille	1.5mm Thickness Steel, Hexagonal mesh, acoustic foam lined
Transport Wheels	4pcs Heavy duty 100mm PU castors included in the box
Unit dimensions (HWD)	562 x 1080 x 685mm, (22.1" x 42.5" x 27")
Unit weight	74.7Kg, 165 lbs
Carton dimensions (HWD)	700 x 1280 x 815mm, (27.6" x 50.4" x 32.1"), (0.73 M3)
Packed weight	88Kg, 194 lbs
EAN13	tbc

1 AES standard Pink Noise 12dB crest factor 2 hours
2 Measured in Half space (2π) conditions
3 Calculated maximum SPL based on rated power handling



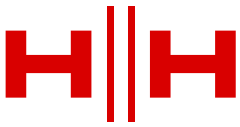

TNA ACTIVE SUBWOOFER

T E S S E N

LIVE SOUND & INSTALLATION

DIMENSIONS (in mm)

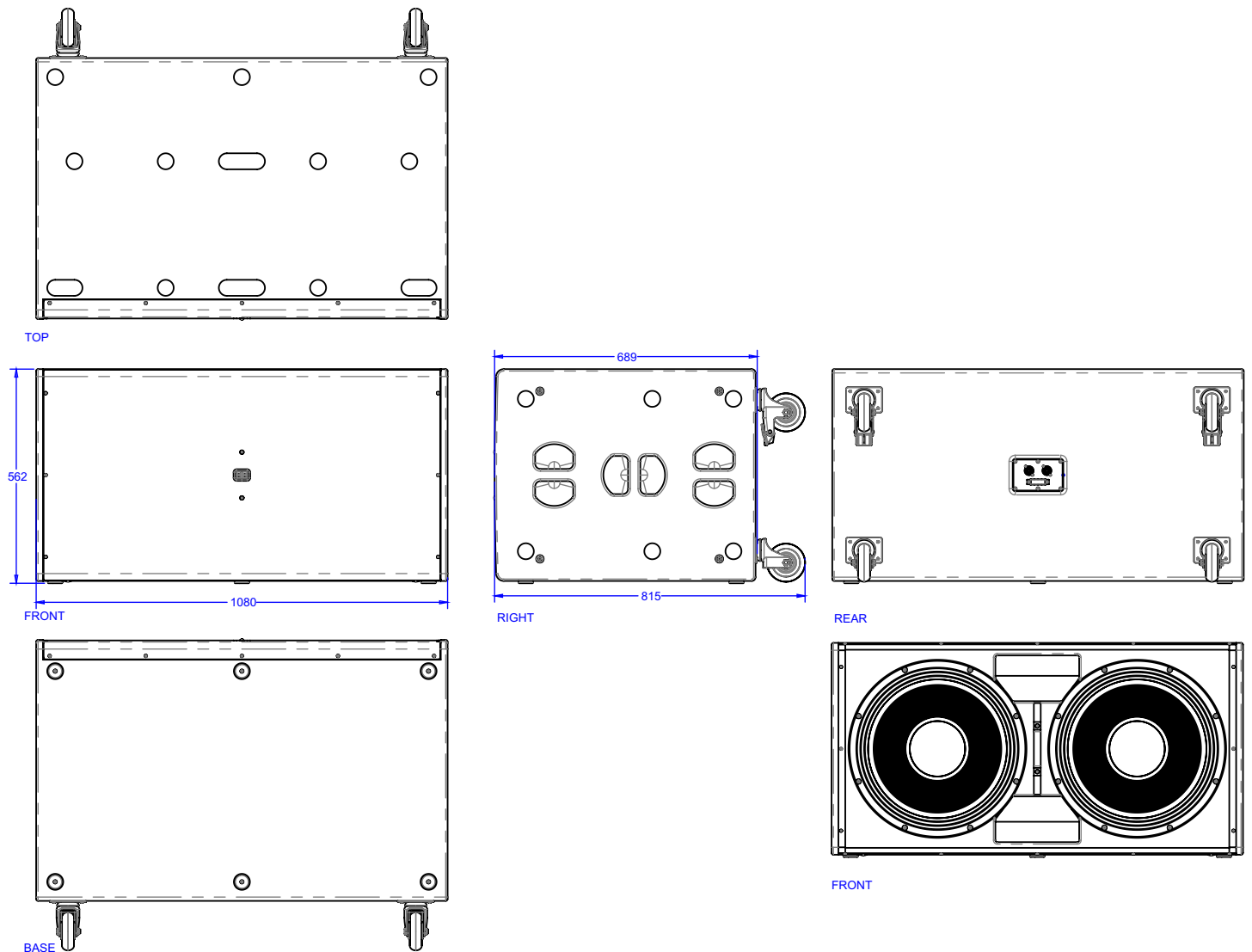
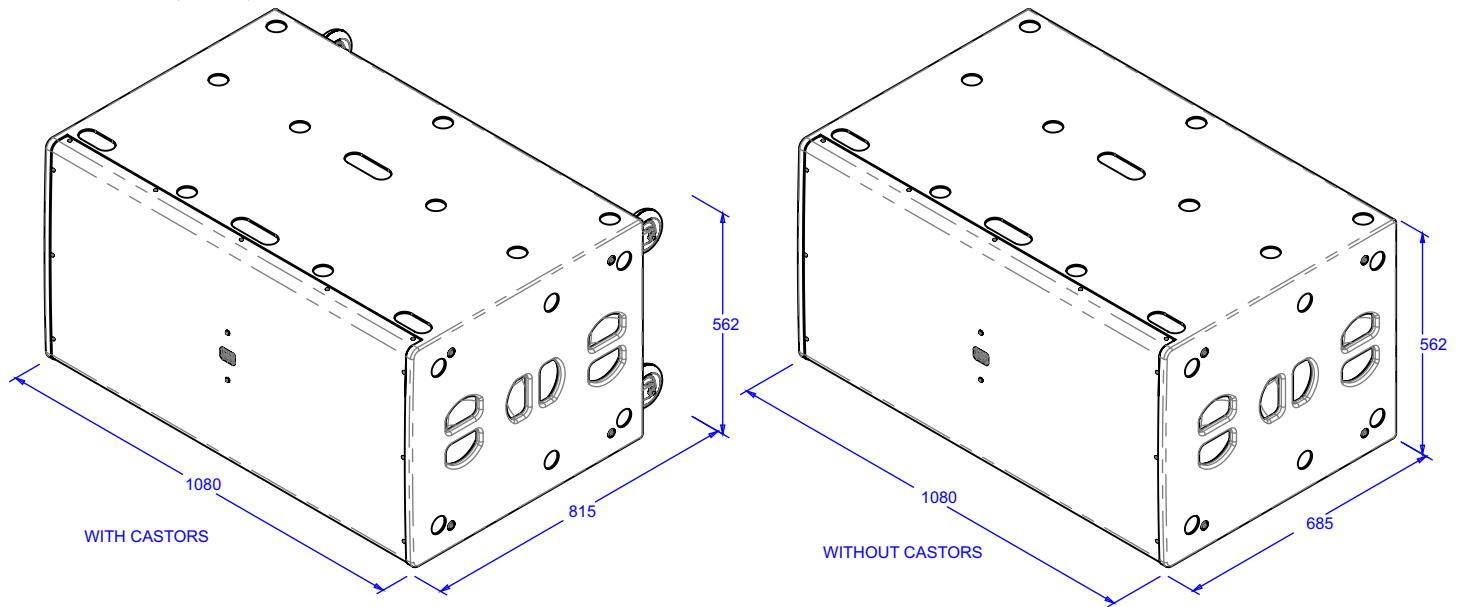

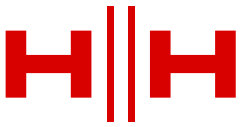

TNA ACTIVE SUBWOOFER

T E S S E N

LIVE SOUND & INSTALLATION

FREQUENCY RESPONSE

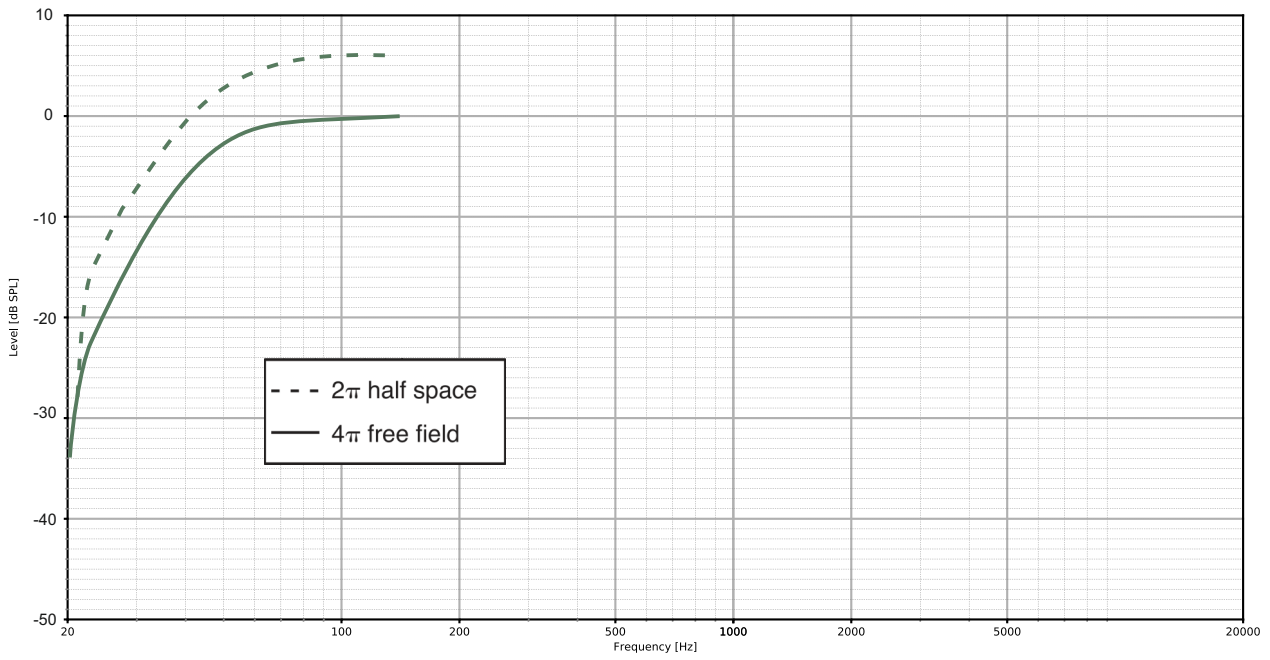

REAR WITH CASTORS FITTED

