



TENSOR-MINI

USER MANUAL



CONTENTS

TENSOR-MINI OVERVIEW.....	2
FEATURES	2
CONTROLS	3
CHANNEL 1 & 2.....	3
LINE OUT & CHANNEL 3.....	4
BLUETOOTH AND USB CONTROLS	5
MAINS INLET	5
SETUP	6
MULTI-POSITION	6
BLUETOOTH CONNECTIVITY	6
USB PLAYBACK	8
EQ SETTINGS.....	9
BATTERY LEVEL.....	9
SPECIFICATIONS	10
DIMENSIONS (in mm).....	11
SAFETY AND WARNINGS.....	12



TENSOR-MINI OVERVIEW

The ultra portable Tensor-MINI is an easy to carry, lightweight, high power PA loudspeaker with built in Li-Ion Battery. The versatile preamp includes a 3 channel mixer, DSP and reverb effects along with a Bluetooth/USB media player. Bluetooth also supports stereo linking of two units. The multi-angle cabinet can be used on the ground, as a monitor or on a pole stand and the user controlled EQ adjustment ensures you can always get optimal sound quality. The Tensor-MINI is ideal for Performers/Vocalists/Parties and more.

FEATURES

- Ultra compact, lightweight design
- 6.5" Co-Axial full range driver
- High power amplifier
- 3 channel Mic/Line/Instrument mixer with reverb
- Bass/Treble control
- Internal Li-Ion battery powered
- Media player with Bluetooth audio streaming and stereo linking
- USB media player capabilities

CONTROLS

CHANNELS 1 & 2

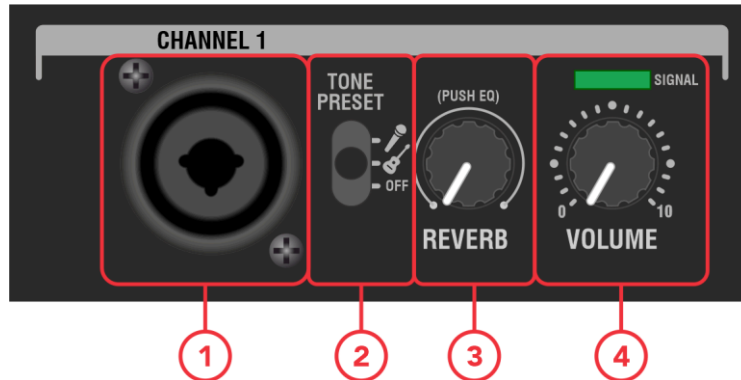

1. XLR/6.3mm COMBI SOCKETS

Channel 1 and 2 inputs take either XLR or 6.3mm jack. Can connect balanced or unbalanced signals.

2. TONE PRESET SWITCH

Select between Mic, Instrument or Line mode for the channel.

3. REVERB LEVEL

Set the reverb level for the respective channel (available on 1 and 2), current level will show on the LCD below. Push this to instead edit the bass/treble levels for the channel, again visible on the LCD.

4. VOLUME LEVEL AND SIGNAL INDICATOR

Volume level controls the preamp gain for that channel. Set to minimum when first setting up and increase gradually to a suitable volume.

Signal indicator LED shows green when a signal is present on the channel and red when the signal is clipping. Occasional red flashes are ok but avoid constant illumination of the red light. Turn the volume down on your device or the MINI if so.

LINE OUT & CHANNEL 3

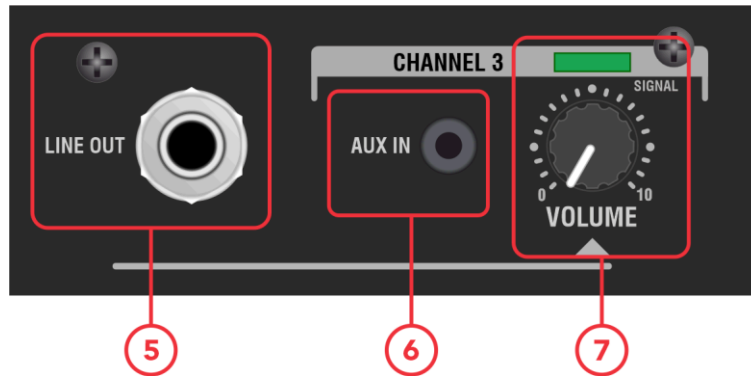

5. LINE LEVEL OUT

6.3mm line level output to link to other devices. This will be the same mix of all 3 channels that plays out of the speaker but at a line level. Also the output for this is post EQ so the bass, treble and reverb settings will be applied.

6. AUX INPUT

3.5mm stereo aux socket. A line level input for audio use.

7. VOLUME LEVEL AND SIGNAL INDICATOR

Control the volume for the aux input as well as the USB and Bluetooth inputs.

Signal indicator LED shows green when a signal is present on the channel and red when the signal is clipping. Occasional red flashes are ok but avoid constant illumination of the red light. Turn the volume down on your input device or the Tensor-MINI if so.

BLUETOOTH AND USB CONTROLS

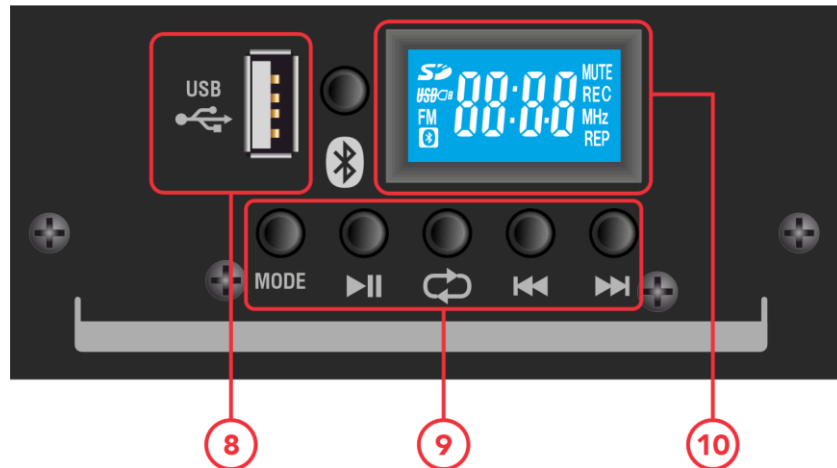

8. USB SOCKET

Connect your mobile phone or USB flash drive here to use USB channel of the Tensor-MINI.

9. PLAYBACK CONTROLS

Used to control the playback for USB and Bluetooth audio, cycle through USB folders, set the mode for channel 3 and enter EQ adjustment. For more info see [USB Playback \(Page 7\)](#).

10. LCD

Display screen for outlining Bluetooth and USB playback as well as indicating EQ settings.

MAINS INLET

11. POWER SWITCH

Turns the system on and off. It is good practice to keep the master volume at minimum when switching on and off.

12. C7 IEC MAINS SOCKET

C7 type IEC input to connect with the provided mains lead. Accepts universal voltage 100-240V~.

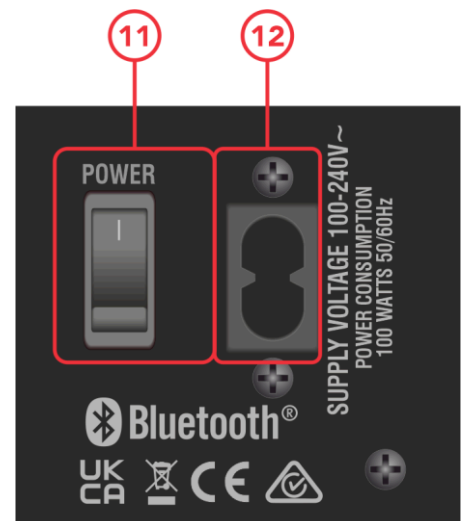



SETUP

MULTI-POSITION

Depending on your use case, the Tensor-MINI can be used in various positions:



Pole-Mounted



Floor Standing



30° Lean Back



Horizontal Monitor

BLUETOOTH CONNECTIVITY

MONO

To connect a device, such as a mobile phone, press the MODE button so that the letters "bt" show on the LCD display, alongside a flashing Bluetooth symbol on the bottom left. The MINI is now looking for a device to pair to.

On your device's Bluetooth settings, find the device named "TENSOR-MINI" and connect to it. Upon pairing, the Bluetooth logo will stop flashing to signal a connection.

Songs can be paused/resumed with the play/pause button and skipped/backtracked using the forward/backward buttons.

To unpair from a Bluetooth connected device, simply hold down the Play/Pause button for approx. 1-2 seconds. Will only work whilst in Bluetooth mode.





STEREO

To connect two Tensor-MINIs via TWS, have both speakers on Bluetooth mode and hold the shuffle button on one for 3 seconds to enter pairing mode. The screen will show "bt - n".



Hold down the same button on the other unit to activate TWS on it. Both Tensor-MINIs will pair together and their screens will show "bt-L" and "bt-R" to indicate the left and right channels.



When they're linked, you can pair your mobile device as usual.



USB PLAYBACK

A USB flash drive can be plugged into the USB socket on the back of the MINI to play audio from. The USB can contain multiple folders of music that can be played individually or shuffled together.

Use the "MODE" button to cycle between the Bluetooth input and the USB input for channel 3. If nothing is plugged into the USB socket, or if the device is not compatible, "NO" will appear on the LCD.

With usable USB plugged in, the word USB will show as well as the runtime of the current audio track.

Whilst in USB mode, cycle through the tracks in the current folder using the forward/backward buttons on the right. Pause or resume the current track with the play/pause button.



By holding the play button for 1-2 seconds, it is also possible to navigate through the USB folders via the forward/backward buttons.

The shuffle button will cycle through different playback modes, with the currently selected mode displayed on the LCD when pressed. "ALL" will play through all tracks available. "ONE" plays the current track then stops. "RAND" is a random shuffle of the available tracks.



PLAYBACK CONTROLS

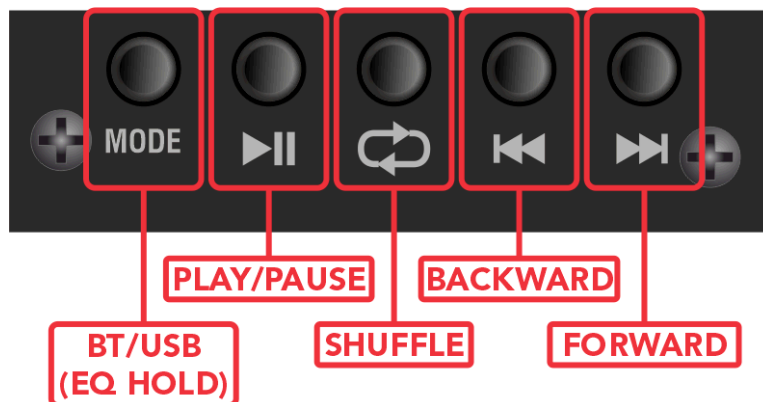



EQ SETTINGS

All 3 channels can have their own bass, treble and reverb settings modified through the controls on the Tensor-MINI.

For channels 1 and 2, push in the reverb knob to modify the EQ for the respective channel. For channel 3, hold the "MODE" button for 1-2 seconds until the "H" (high frequency level) shows on the LCD. The current set level shows on the right hand side and can go from -10 to +10. A minus sign appears to the right of the "H" to indicate a negative value.

Use the reverb knob or the rewind/skip buttons to increase or decrease the value.

Press the reverb knob (CH1/2) or "MODE" (CH3) button again to change the bass/low frequency level, again ranging from -10 to +10.

Press the reverb knob again (CH1/2 only) to modify the reverb - "RE" level of the channel. This ranges from 0 to +16.



BATTERY LEVEL

The battery level and charging status are both indicated by the LED found on the top of the Tensor-MINI. Be sure to keep an eye on this display whilst in use, especially if the power cable is not connected.

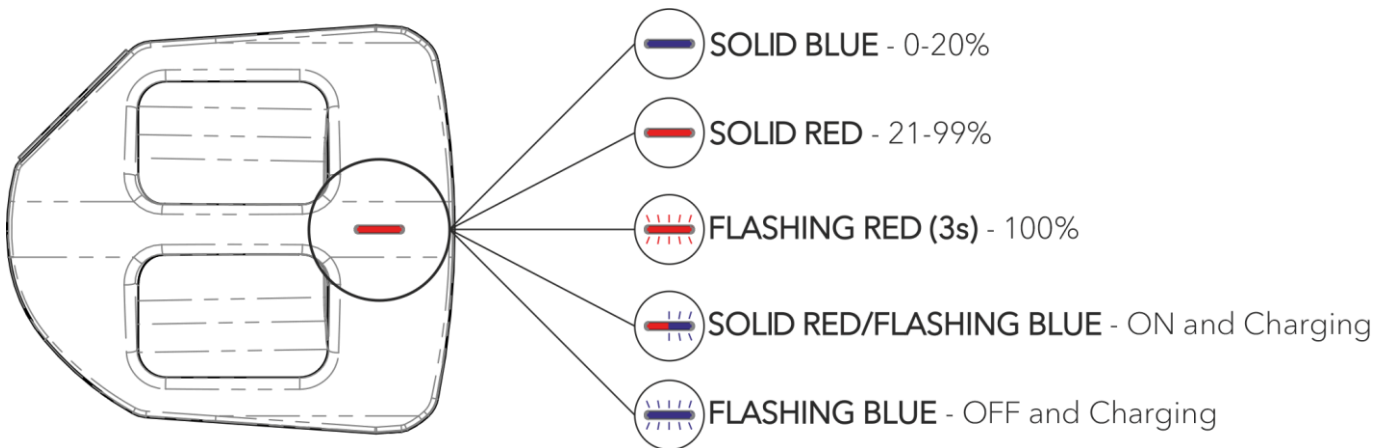



SPECIFICATIONS

Model	Tensor-MINI
System Type	Ultra Portable Battery Powered PA Speaker
Frequency Response	55-20kHz
Max SPL (1M)	110 dB SPL, 121 dB SPL (Peak) Full Space
Features	
Mixer	3 Channel Mixer
Effects	Reverb
EQ	CH1/2 Bass/Treble and Tone Preset for Mic/Instrument modes.
Channel 1/2 Features	Combo (XLR/Jack) balanced/unbalanced input with Mic/Instrument/Line preset switch. Reverb, EQ, Volume and signal/peak LED
Channel 3 Features	3.5mm Stereo Aux In, Bluetooth Media Player with USB Playback. Volume Control and signal/peak LED
Outputs	6.3mm Line Out Jack
Loudspeaker	6.5" HH Designed Coaxial Woofer
Horizontal Coverage	100°
Vertical Coverage	80°
Amplifier/Power	
Power Rating	400W Peak, 100W RMS
Amplifier Type	Class D Bi-AMP
Power Supply	Universal 100-240V~ 50/60Hz Input (C7 IEC Connector)
Power Consumption	100W
Battery	Internal 14.4V/5AH (72WH) Li-Ion Battery. Up to 12 Hours Play Time, 5 Hours Charge Time
Other	Battery status LED (Charging, <25%, 50-90%, 100%)
Protection	Short circuit, Thermal overload, multi band limiter
Cooling	Convection
Enclosure	
Cabinet	Robust ABS Enclosure with Powdercoated steel grille with acoustic foam backing
Finish	Black
Other	Illuminating HH Logo
Dimensions	
Unit dimensions (HWD)	343 x 258 x 283.5 mm, (13.5" x 10.2" x 11.2")
Net Weight	7.5Kg, 16.5 lbs
Carton dimensions (HWD)	400 x 330 x 310 mm, (15.7" x 13" x 12.2") (0.041 M3)
Gross Weight	8.2Kg, 18.1 lbs
EAN13	5060109458794



DIMENSIONS (in mm)

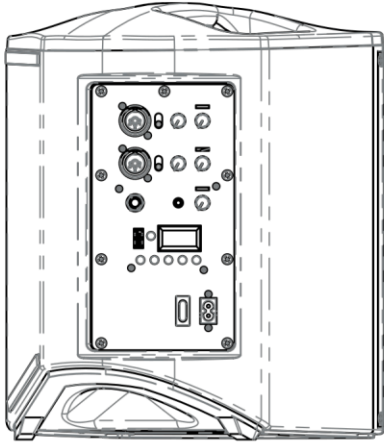

REAR PANEL

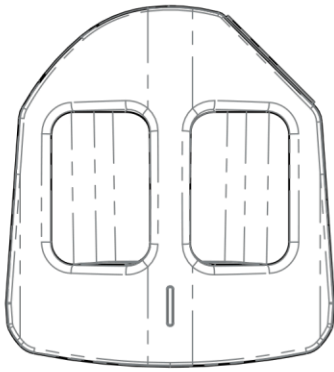
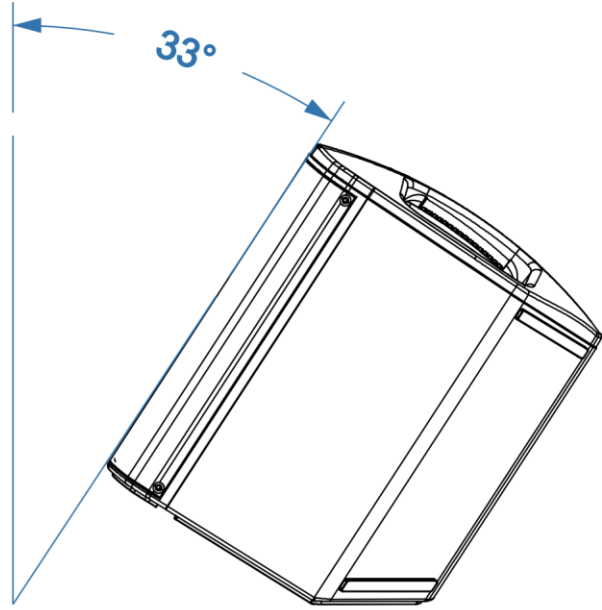

TOP

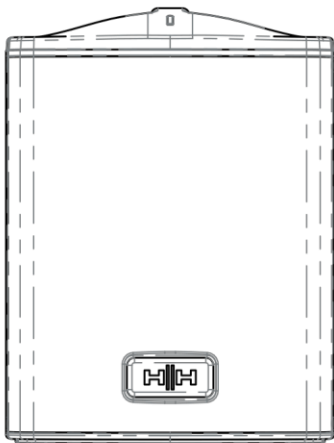
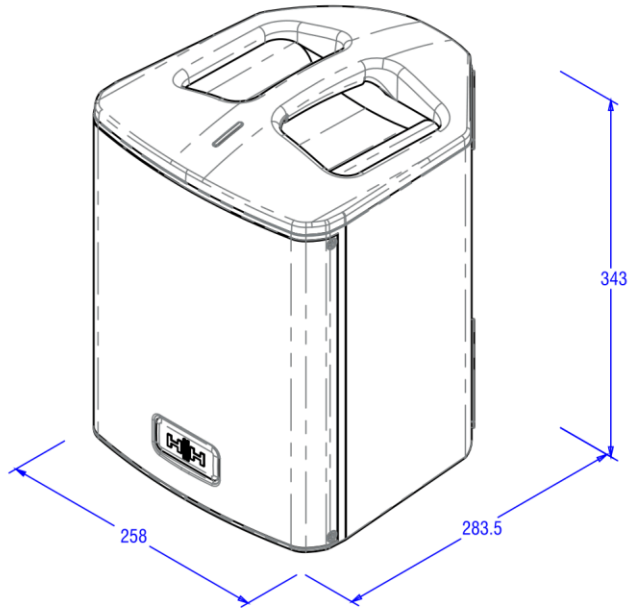

FRONT

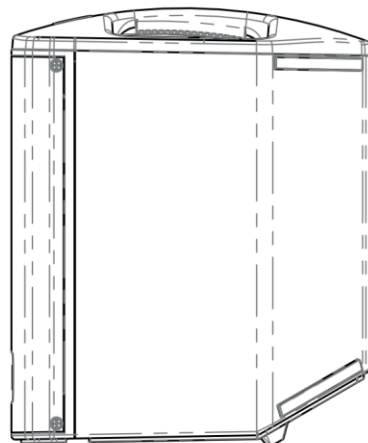

RIGHT

SAFETY AND WARNINGS

To take full advantage of your new product and enjoy long and trouble-free performance, please read this owner's manual carefully, and keep it in a safe place for future reference.

- 1) Unpacking: On unpacking your product, please check carefully for any signs of damage that may have occurred whilst in transit from the HH factory to your dealer. In the unlikely event that there has been damage, please re-pack your unit in its original carton and consult your dealer. We strongly advise you to keep your original transit carton, since in the unlikely event that your unit should develop a fault, you will be able to return it to you dealer for rectification securely packed.
- 2) Amplifier Connection: To avoid damage, generally it is advisable to establish and follow a pattern for turning on and off your system. With all system parts connected, turn on source equipment, mixers, effects processors etc, BEFORE turning on your amplifier. Many products have large transient surges at turn on and off which can cause damage to your speakers. By turning on your amplifier LAST and making sure its level control is set to a minimum, any transients from other equipment should not reach your loudspeakers. Wait till all system parts have stabilised, usually a couple of seconds. Similarly, when turning off your system always turn down the level controls on your amplifier and then turn off its power before turning off other equipment.
- 3) Cables: Never use shielded or microphone cable for any speaker connections as this will not be substantial enough to handle the amplifier load and could cause damage to your complete system. Use good quality shielded cables everywhere else.
- 4) Servicing: The user should not attempt to service these products. Refer all servicing to qualified service personnel.
- 5) Heed all warnings.
- 6) Follow all instructions.
- 7) Do not use this apparatus near water.
- 8) Clean only with a dry cloth.
- 9) Do not block any of the ventilation openings. Install in accordance with manufacturer's instructions.
- 10) Do not install near any heat sources such as radiators, heat registers, stoves, or other apparatus (including amplifiers) that produce heat.
- 11) An apparatus with Class I construction shall be connected to a mains socket outlet with a protective connection. Do not defeat the safety purpose of the polarized or grounding-type plug. A polarized plug has two blades with one wider than the other. A grounding type plug has two blades and a third grounding prong. The wide blade or third prong is provided for your safety. If the provided plug does not fit into your outlet, consult an electrician for replacement of the obsolete outlet.
- 12) Protect the power cord from being walked on or pinched, particularly at plugs, convenience receptacles, and the point they exit from the apparatus.
- 13) Only use attachments/accessories provided by the manufacturer.
- 14) Use only with a cart, stand, tripod, bracket, or table specified by the manufacturer, or sold with the apparatus. When a cart is used, use caution when moving the cart/apparatus combination to avoid injury from tip-over.
- 15) The mains plug or appliance coupler is used as the disconnect device and shall remain readily operable. The user should allow easy access to any mains plug, mains coupler and mains switch used in conjunction with this unit thus making it readily operable. Unplug this apparatus during lightning storms or when unused for long periods of time.
- 16) Refer all servicing to qualified service personnel. Servicing is required when the apparatus has been damaged in any way, such as when power-supply cord or plug is damaged, liquid has been spilled or objects have fallen into the apparatus, the apparatus has been exposed to rain or moisture, does not operate normally, or has been dropped.
- 17) Never break off the ground pin. Connect only to a power supply of the type marked on the unit adjacent to the power supply cord.
- 18) If this product is to be mounted in an equipment rack, rear support should be provided.
- 19) Note for UK only: If the colours of the wires in the mains lead of this unit do not correspond with the terminals in your plug, proceed as follows:
 - o The wire that is coloured green and yellow must be connected to the terminal that is marked by the letter E, the earth symbol, coloured green or coloured green and yellow.
 - o The wire that is coloured blue must be connected to the terminal that is marked with the letter N or the colour black.
 - o The wire that is coloured brown must be connected to the terminal that is marked with the letter L or the colour red.
- 20) This electrical apparatus should not be exposed to dripping or splashing and care should be taken not to place objects containing liquids, such as vases, upon the apparatus.
- 21) Exposure to extremely high noise levels may cause a permanent hearing loss. Individuals vary considerably in susceptibility to noise-induced hearing loss, but nearly everyone will lose some hearing if exposed to sufficiently intense noise for a sufficient time. The U.S. Government's Occupational Safety and Health Administration (OSHA) has specified the following permissible noise level exposures: According to OSHA, any exposure more than the above permissible limits could result in some hearing loss. Earplugs or protectors to the ear canals or over the ears must be worn when operating this amplification system to prevent a permanent hearing loss, if exposure is more than the limits as set forth above. To ensure against potentially dangerous exposure to high sound pressure levels, it is recommended that all persons exposed to equipment capable of producing high sound pressure levels such as this amplification system be protected by hearing protectors while this unit is in operation.
- 22) If your appliance features a tilting mechanism or a kickback style cabinet, please use this design feature with caution. Due to the ease with which the amplifier can be moved between straight and tilted back positions, only use the amplifier on a level, stable surface. DO NOT operate the amplifier on a desk, table, shelf or otherwise unsuitable non-stable platform.
- 23) The Bluetooth® word mark and logos are registered trademarks owned by the Bluetooth SIG, Inc. and any use of such marks by Headstock Distribution Ltd is under license. Other trademarks and trade names are those of their respective owners. HH Electronics Ltd. is a registered trademark of Headstock Distribution Ltd.
 - o INCORPORATED RADIO EQUIPMENT DEVICE TECHNICAL SPECIFICATION:
 - o Frequency Range: 2402-2480MHz
 - o Transmit Power: +2dBm (1.6mW)
 - o Receiver Sensitivity: -91dBm
 - o Operating Protocol: Bluetooth Class 2
 - o Bluetooth V5.0
- 24) Symbols & nomenclature used on the product and in the product manuals, intended to alert the operator to areas where extra caution may be necessary, are as follows:

Duration Per Day in Hours	Sound Level dBA, slow response
8	90
6	92
4	95
3	97
2	100
1 ½	102
1	105
½	110
¼ ou inférieur	115

 CAUTION:	<p>Intended to alert the user to the presence of uninsulated 'Dangerous Voltage' within the products enclosure that may be sufficient to constitute a risk of electrical shock to persons.</p> <p>Ce symbole est utilisé pour indiquer à l'utilisateur de ce produit de tension non-isolée dangereuse pouvant être d'intensité suffisante pour constituer un risque de choc électrique.</p> <p>Este símbolo tiene el propósito de alertar al usuario de la presencia de '(voltaje) peligroso' que no tiene aislamiento dentro de la caja del producto que puede tener una magnitud suficiente como para constituir riesgo de corrientazo.</p> <p>Dieses Symbol soll den Anwender vor unisolierten gefährlichen Spannungen innerhalb des Gehäuses warnen, die von ausreichender Stärke sind, um einen elektrischen Schlag verursachen zu können.</p>
 WARNING:	<p>Intended to alert the user of the presence of important operating and maintenance (Servicing) instructions in the literature accompanying the product.</p> <p>Dieses Symbol soll den Anwender vor unisolierten gefährlichen Spannungen innerhalb des Gehäuses warnen, die von ausreichender Stärke sind, um einen elektrischen Schlag verursachen zu können.</p> <p>Este símbolo tiene el propósito de alertar al usuario de las presencias de instrucciones importantes sobre la operación y mantenimiento en la literatura que viene con el producto.</p> <p>Dieses Symbol soll den Benutzer auf wichtige Instruktionen in der Bedienungsanleitung aufmerksam machen, die Handhabung und Wartung des Produkts betreffen.</p>
<p>CAUTION:</p> <p>ATTENTION :</p> <p>PRECAUCION:</p> <p>VORSICHT:</p>	<p>Risk of electrical shock - DO NOT OPEN. To reduce the risk of electrical shock, do not remove the cover. No user serviceable parts inside. Refer servicing to qualified personnel.</p> <p>Risques de choc électrique - NE PAS OUVIRIR. Afin de réduire le risque de choc électrique, ne pas enlever le couvercle. Il ne se trouve à l'intérieur aucune pièce pouvant être réparée par l'utilisateur. Confier l'entretien à un personnel qualifié.</p> <p>Riesgo de descarga eléctrica - NO ABRIR. Para reducir el riesgo de descarga eléctrica, no quite la cubierta. No hay piezas reparables por el usuario en el interior. Remita el servicio a personal calificado.</p> <p>Risiko - Elektrischer Schlag! Nicht offen! Um das Risiko eines elektrischen Schlages zu vermeiden, nicht die Abdeckung entfernen. Es befinden sich keine Teile darin, die vor Anwender repariert werden konnten. Reparaturen nur von qualifiziertem Fachpersonal durchführen lassen.</p>
<p>WARNING:</p> <p>ADVERTISSEMENT :</p> <p>ADVERTENCIA:</p> <p>ACHTUNG:</p>	<p>To prevent electrical shock or fire hazard, do not expose this appliance to rain or moisture. Before using this appliance, please read the operating instructions for further warnings.</p> <p>Afin de prévenir les risques de décharge électrique ou de feu, n'exposez pas cet appareil à la pluie ou à l'humidité. Avant d'utiliser cet appareil, lisez les avertissements supplémentaires situés dans le guide.</p> <p>Para evitar descargas eléctricas o peligro de incendio, no exponga este aparato a la lluvia ni a la humedad. Antes de usar este aparato, lea las instrucciones de funcionamiento para conocer más advertencias.</p> <p>Um einen elektrischen Schlag oder Feuergefahr zu vermeiden, sollte dieses Gerät nicht dem Regen oder Feuchtigkeit ausgesetzt werden. Vor Inbetriebnahme unbedingt die Bedienungsanleitung lesen.</p>
	<p>This device complies with Part 15 of the FCC rules Operation is subject to the following two conditions:</p> <ol style="list-style-type: none"> 1) This device may not cause harmful interference. 2) This device must accept any interference received, that may cause undesired operation. <p>Warning: Changes or modification to the equipment not approved by HH can void the user's authority to use the equipment.</p> <p>Note: This equipment has been tested and found to comply with the limits for Class B digital device, pursuant to Part 15 of the FCC Rules. These limits are designed to provide reasonable protection against harmful interference in a residential installation. This equipment generates, uses and can radiate radio frequency energy and if not installed and used in accordance with the instructions, may cause harmful interference to radio communications. However, there is no guarantee that interference will not occur in a particular installation. If this equipment does cause harmful interference to radio or television reception, which can be determined by turning the equipment off and on, the user is encouraged to try and correct the interference by one or more of the following measures. Reorient or relocate the receiving antenna. Increase the separation between the equipment and receiver. Connect the equipment into an outlet on a circuit different from that to which the receiver is connected. Consult the dealer or an experienced radio/TV technician for help.</p>
	<p>This product conforms to the requirements of the following European Regulations, Directives & Rules: CE Mark (93/68/EEC), Low Voltage 2014/35/EU, EMC (2014/30/EU), RoHS (2011/65/EU), RED (2014/30/EU), ErP 2009/125/EU</p> <p>SIMPLIFIED EU DECLARATION OF CONFORMITY</p> <p>Hereby, HH Electronics declares that the radio equipment is in compliance with Directives 2014/53/EU, 2011/65/EU, 2009/125/EU</p> <p>Full text of the EU declaration of conformity is available at the following internet address:</p> <p>http://support.hhelectronics.com/approvals</p>
	<p>The object of the declaration described above is in conformity with the relevant statutory requirement Radio Equipment Regulations 2017, The Restriction of the use of Certain Hazardous Substances in Electrical and Electronic Equipment Regulations 2012, The Ecodesign for Energy-Related Products and Energy Information (Amendment) (EU Exit) Regulations 2012.</p>
	<p>In order to reduce environmental damage, at the end of its useful life, this product must not be disposed of along with normal household waste to landfill sites. It must be taken to an approved recycling centre according to the recommendations of the WEEE (Waste Electrical and Electronic Equipment) directive applicable in your country.</p>

HH ELECTRONICS LTD.
STEELPARK ROAD, COOMBSWOOD BUSINESS PARK WEST, HALESOWEN, B62 8HD
HH ELECTRONICS PART OF HEADSTOCK GROUP
FOR THE LATEST INFORMATION PLEASE VISIT

WWW.HHELECTRONICS.COM

**IN THE INTEREST OF CONTINUED DEVELOPMENT, HH RESERVES THE RIGHT TO AMEND PRODUCT SPECIFICATION
WITHOUT PRIOR NOTIFICATION.**

V0.2